



Sustainable Sensors

Jim Honeyman

jim@4volts.com

Dr Mark Glickman

drmarkglickman@yahoo.com

Water Sensor

- This circuit can be made without a transistor.
- However, transistor can drive higher current loads.

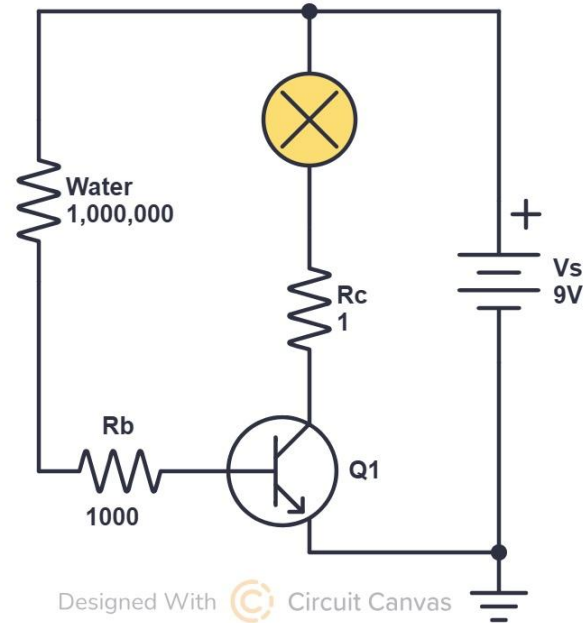

Water Sensor

- Circuit photo:

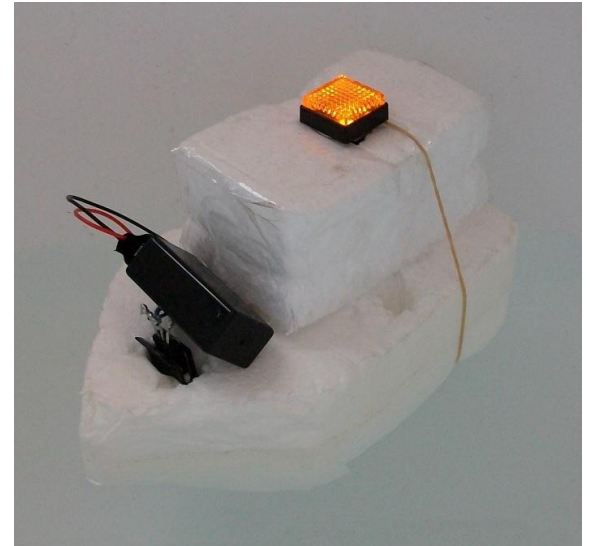
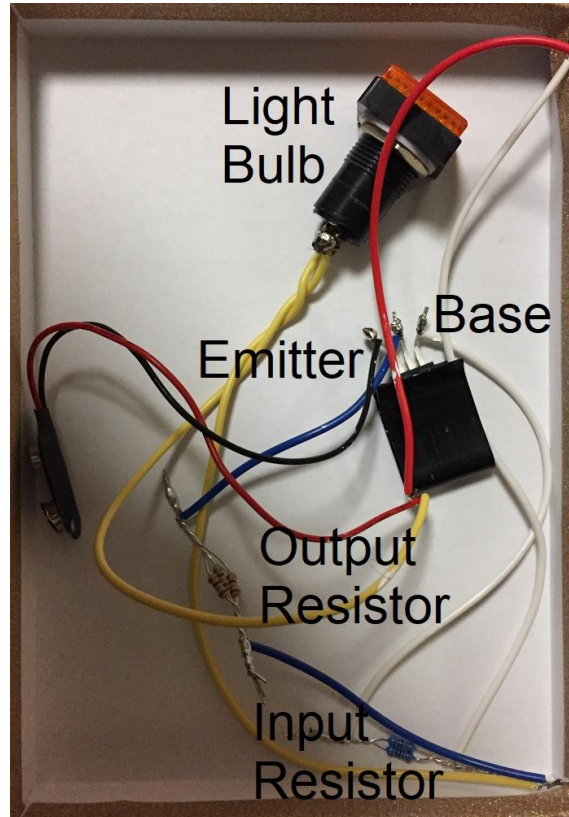



Water Sensor



Water Boat

- Circuit:

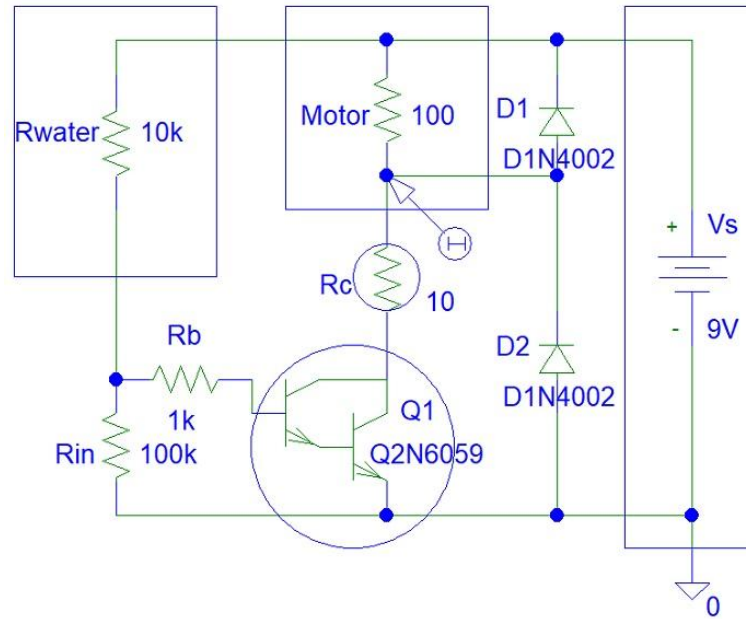



Water Boat

- Photos:

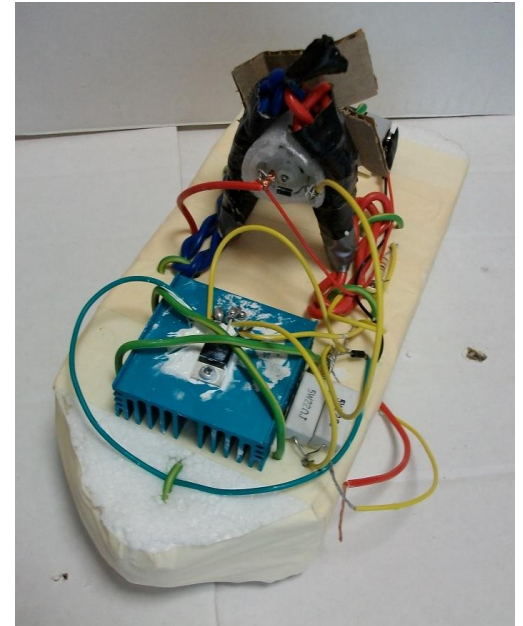
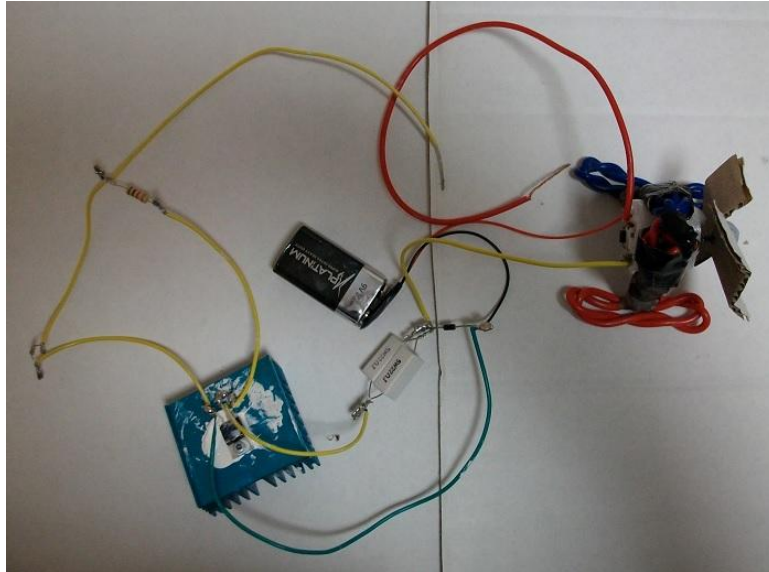

Water Boat



Touch Lamp

- You actually do not need three transistors.
- The circuit can work with two transistors.
- However, used transistors have low current gain.
- Rb2 and Re3 resistors are optional.

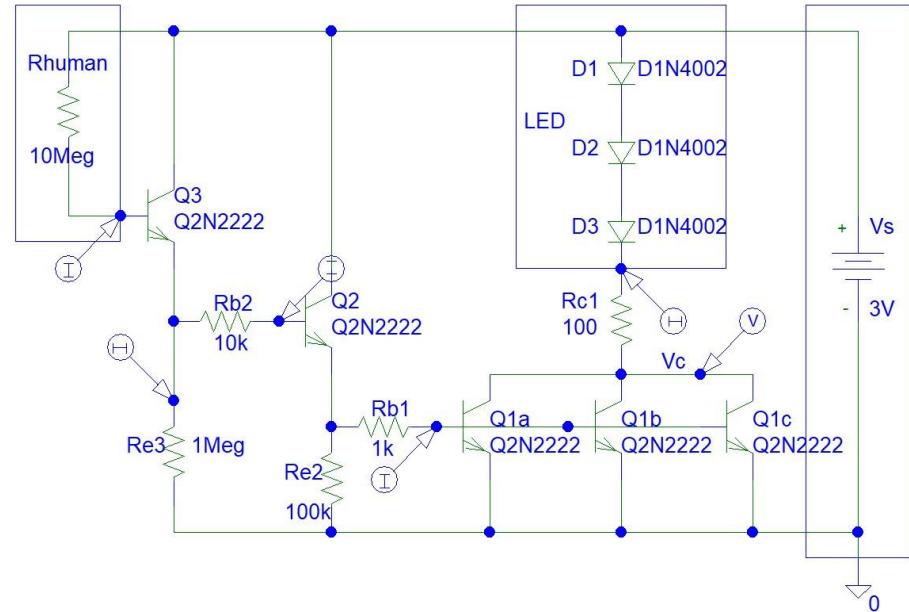

Security Systems

- Circuit design:

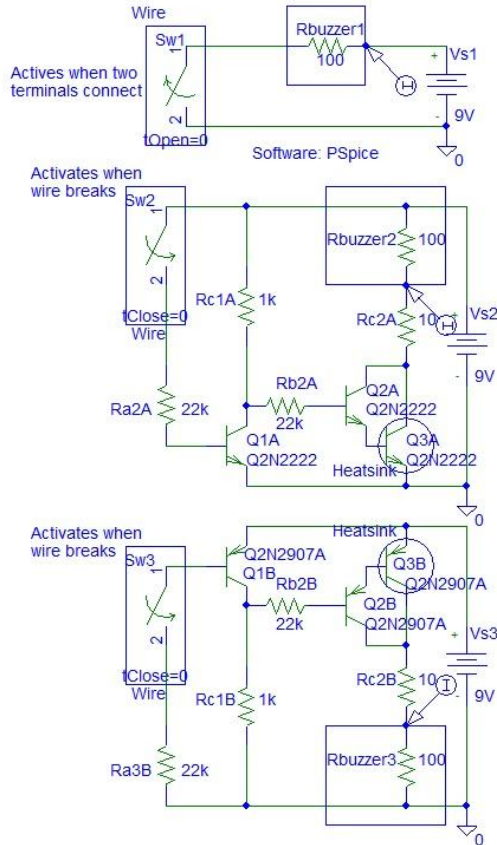



References

1. <https://instructables.com/member/recycledcircuits>
2. <https://hackaday.io/recycledcircuits>
3. <https://instructables.com/member/recycledcomponents>
4. <https://hackaday.io/recycledcomponents>
5. <https://instructables.com/member/usedcomponents>
6. <https://hackaday.io/usedcomponents>
7. <https://instructables.com/member/recycledplanets>
8. <https://hackaday.io/recycledplanets>
9. <https://instructables.com/member/recycledsculptures>
10. <https://hackaday.io/recycledsculptures>



References

1. <https://instructables.com/member/diyelectronics>
2. <https://hackaday.io/diyelectronics>
3. <https://instructables.com/member/simplecircuits>
4. <https://hackaday.io/simplecircuits>
5. <https://instructables.com/member/cheapcircuits>
6. <https://hackaday.io/cheapcircuits>
7. <https://instructables.com/member/supercircuits>
8. <https://hackaday.io/supercircuits>
9. <https://instructables.com/member/basicmechanics>
10. <https://hackaday.io/basicmechanics>



References

1. <https://instructables.com/member/webaerospace>
2. <https://hackaday.io/webaerospace>
3. <https://instructables.com/member/webphotos>
4. <https://hackaday.io/webphotos>
5. <https://instructables.com/member/simplecomponents>
6. <https://hackaday.io/simplecomponents>
7. <https://instructables.com/member/cheapcomponents>
8. <https://hackaday.io/cheapcomponents>
9. <https://instructables.com/member/lowcostcircuits>
10. <https://hackaday.io/lowcostcircuits>